

# FIREPRO CENTABUILD

HEAD OFFICE: AUCKLAND (09) 579 0367  
WELLINGTON (04) 568 7086 • CHRISTCHURCH (03) 379 9364  
www.firepro.co.nz sales@firepro.co.nz

CI/SfB

FG40 DATASHEET - 17/02/10

Product specifications can change. Contact us to ensure you have our latest datasheet

## FG40 FIRE STOP INTUMESCENT GRILL/FIRE DAMPER (Multi-purpose with Architectural Finish).

Firepro FG40 Fire Grills are designed to protect apertures in fire resistant structures. Under normal conditions they allow free flowing ventilation, however in the event of a fire they will rapidly seal off the opening to provide complete fire integrity. The grills are attractive, simple to install and very economical.

Major applications include air ventilation through fire-rated walls and floors and in metal ducting penetrating floors and walls.

### CONSTRUCTION

The units are constructed from rigid PVC extrusions of hollow cross section which is filled with intumescent material. They are robust, easily cleaned and have no moving parts to require maintenance.

### OPERATION

Under fire conditions the intumescent core expands and the casing becomes soft and pliable, allowing rapid unrestrained expansion of the core. The intumescent core has a low response temperature and rapid response time, quickly expanding to many times its original thickness, forming a firm non-combustible fire seal.

### TEST DATA

#### Walls (concrete, brick or plasterboard)

Up to 2 hours fire integrity (-/120/-) for circular grills up to 300mm diameter, square grills up to 450mm x 450mm, or rectangular grills up to 0.2M<sup>2</sup> with a maximum of 600mm on one side in plasterboard, brick or concrete walls.

Tested to AS1530:4 and BS476:20-22.

#### Floors

Up to 2 hours integrity (-/120/-) in concrete floors for circular grills up to 300mm diameter or 200mm x 200mm and 1 hour integrity (-/60/-) in floors for 450mm x 450mm square or rectangular up to 0.2M<sup>2</sup> with a maximum of 600mm on one side. Tested in 120mm concrete floor to AS1530:4 & BS476:20-22.

Note: For larger intumescent grills see Firepro FG50 - for Insulated Dampers See FD40R.

### FITTING

The unit should be a neat fit in the aperture to be protected and the perimeter sealed with Firepro M707 intumescent mastic.

Fixing of the units is easily accomplished by means of screws, rivets, or brackets. In the case of exposed applications it is recommended that a grill cover be fitted over the FG40.

Galvanised steel spigots, brackets and other accessories are available to aid installation.

See Application Notes overleaf.

### SIZES & AVAILABILITY

A range of 15 popular sizes is normally available ex-stock, other sizes are manufactured in increments of 20mm up to a maximum of 300mm diameter for circular grills, 450mm x 450mm for square and 0.2M<sup>2</sup> for rectangular (eg 600mm x 300mm, 400mm x 500mm, etc). Free area of the FG40 grill is approximately 60%, excluding the perimeter frame.

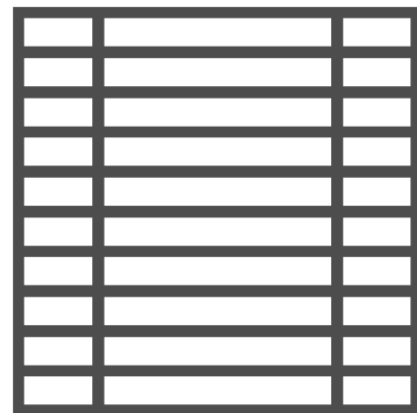
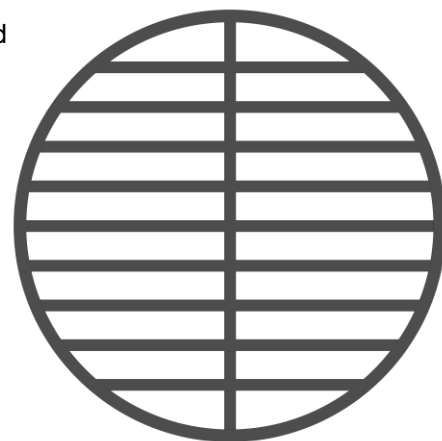

STOCK SIZES: GRILL (Nominal Sizes)		
Square	Rectangular	Circular
150 x 150mm	200 x 400mm	100mm Diameter
200 x 200mm	200 x 600mm	125mm Diameter
300 x 300mm	300 x 400mm	150mm Diameter
400 x 400mm	300 x 600mm	200mm Diameter
450 x 450mm	400 x 500mm	250mm Diameter
		300mm Diameter

Actual sizes are 2-5mm less than nominal to allow tolerance for installation.

NOTE: The technical information and suggestions for use and application presented herein represent the best information available to us and are believed to be reliable. They should not however be construed as controlling suggestions and there is no warranty of performance of our materials either expressed or implied. We urge that users of our materials conduct confirmatory tests to determine final suitability for their specific end uses. All dimensions are nominal. **We reserve the right to make changes or to withdraw designs and products without notice.**

# INSTALLATION INSTRUCTIONS

## FG40 Fire Grills (Round, Square & Rectangular)

### Concrete Floor

- Fix the mounting brackets to sides of hole, with a minimum of 10G x 22mm Wafer Head Self Drilling Screws, using either three or four brackets as per option 1 or 2. Ensure that the mounting bracket is positioned so that when the grill is inserted into the floor that the entire thickness of the grill is within the floor thickness
- Fix mounting brackets, using a minimum 6mm masonry anchor, to top of floor.
- Apply Firepro M707 Fire and Acoustic Mastic around the perimeter of the grill on both sides of the floor ensuring that the mastic is applied to a minimum depth of 15mm between the grill and floor. A maximum clearance of 10mm applies.

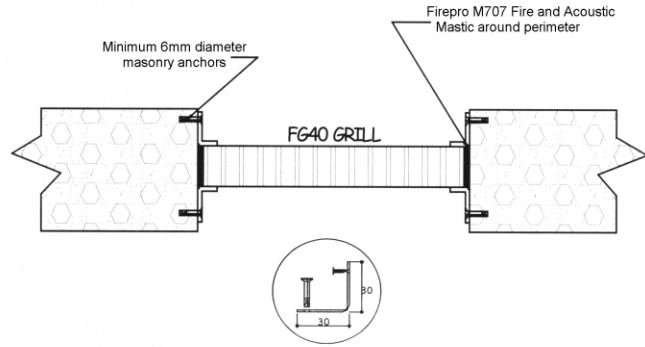

### Masonry Wall

- Position the grill into the opening so that it is central within the wall thickness.
- Apply Firepro M707 Fire and Acoustic Mastic around the perimeter of the grill on both sides of the wall ensuring that the mastic is applied to a minimum depth of 15mm between the grill and wall. Allow a maximum clearance of 10mm around sides.
- (OPTIONAL) Fix the mounting brackets to sides of hole, with a minimum of 10G x 22mm Wafer Head Self Drilling Screws, using either three or four brackets as per option 1 or 2. Ensure that the mounting bracket is positioned so that when the grill is inserted into the wall that the entire thickness of the grill is within the wall thickness

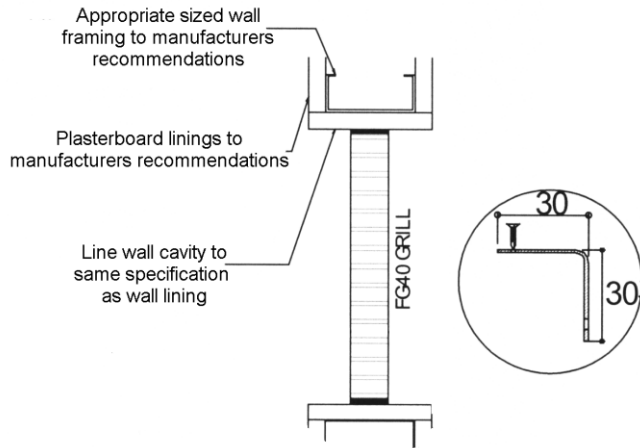
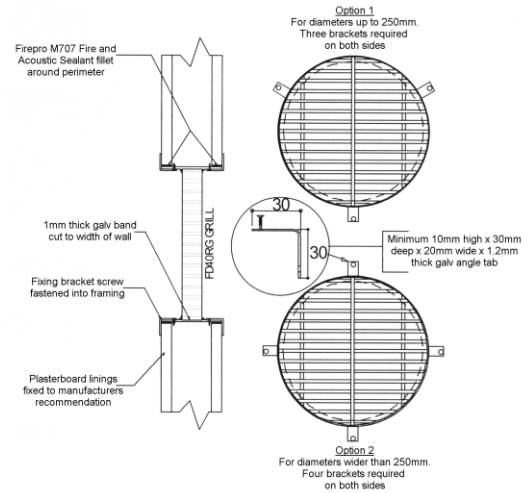

### Plasterboard Walls

**Note:** for circular grills use an FD40 Spigot Damper.

- Line the opening in the wall to the same specification as the wall lining.
- Position the grill into the opening so that it is central within the wall thickness.
- Apply Firepro M707 Fire and Acoustic Mastic around the perimeter of the grill and wall. Allow a maximum clearance of 10mm around sides.
- (OPTIONAL) Fix the mounting brackets to sides of hole, with a minimum of 10G x 22mm Wafer Head Self-drilling Screws, using either three or four brackets. Ensure that the mounting brackets are positioned so that the entire thickness of the grill is within the wall thickness.

### NOTE:

For Installation where the grill is required to be fitted flush with one face of the wall or floor.

- If required, line the opening in the wall to the same specification as the wall lining.
- Fix the 40mm wide mounting brackets to the face of the wall or floor.
- Position the FG40 grill into the opening so that it is flush with the face required.
- Apply a bead of Firepro M707 Fire and Acoustic Mastic around the perimeter of both sides of the grill.
- Install the 30mm x 30mm fixing brackets against the opposite face of the grill.

